

# Dell™ Color Printer 725 User's Guide

Click the links to the left for information on the features and operation of your printer. For information on other documentation included with your printer, see [Finding Information](#).

To order ink or supplies from Dell:

1. Double-click the icon on your desktop.





2. Visit Dell's website: [www.dell.com/supplies](http://www.dell.com/supplies)
3. Order Dell printer supplies by phone. See [Ordering Supplies](#) for the correct phone number for your country.

For the best service, make sure you have the Dell printer Service Tag available. See [Express Service Code and Service Tag number](#) for more information.

---

## Notes, Notices, and Cautions

-  **NOTE:** A NOTE indicates important information that helps you make better use of your printer.
-  **NOTICE:** A NOTICE indicates either potential damage to hardware or loss of data and tells you how to avoid the problem.
-  **CAUTION:** A CAUTION indicates a potential for property damage, personal injury, or death.

Information in this document is subject to change without notice.  
© 2005 Dell Inc. All rights reserved.

Reproduction in any manner whatsoever without the written permission of Dell Inc. is strictly forbidden.



Trademarks used in this text: *Dell* and the *DELL* logo, *Dell Picture Studio*, and *Dell Ink Management System* are trademarks of Dell Inc.; *Microsoft* and *Windows* are registered trademarks of Microsoft Corporation.

Other trademarks and trade names may be used in this document to refer to either the entities claiming the marks and names or their products. Dell Inc. disclaims any proprietary interest in trademarks and trade names other than its own.

Model 725

November 2005 SRV XF819 Rev. A00

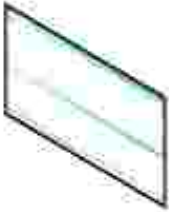
# Finding Information

What are you looking for?	Find it here
<ul style="list-style-type: none"><li>• Drivers for my printer</li><li>• My <i>User's Guide</i></li></ul>	<p><i>Drivers and Utilities CD</i></p>  <p>If you purchased your Dell computer and printer at the same time, documentation and drivers for your printer are already installed on your computer. You can use the CD to uninstall/reinstall drivers or access your documentation.</p> <p>Readme files may be included on your CD to provide last-minute updates about technical changes to your printer or advanced technical reference material for experienced users or technicians.</p>
How to set up my printer	<p><i>Setting Up Your Printer</i> poster</p> 
<ul style="list-style-type: none"><li>• Safety information</li><li>• Warranty information</li></ul>	<p><i>Product Information Guide</i></p> 
Express Service Code and	Express Service Code and Service Tag number

Service Tag number



This label is located under the front cover of the printer.

**NOTE:** The Express Service Code is not available in all countries.

- Latest drivers for my printer
- Answers to technical service and support questions
- Documentation for my printer

Dell Support Website

The Dell Support website provides several online tools, including:

- Solutions - Troubleshooting hints and tips, articles from technicians, and online courses
- Upgrades - Upgrade information for components, such as memory
- Customer Care - Contact information, order status, warranty, and repair information
- Downloads - Drivers
- Reference - Printer documentation and product specifications

- How to use Windows XP
- Documentation for my printer

Windows XP Help and Support Center

1. Click Start→ Help and Support.
2. Type a word or phrase that describes your problem, and then click the arrow icon.
3. Click the topic that describes your problem.
4. Follow the instructions shown on the screen.

# About Your Printer

- [Understanding the Printer Parts](#)
  - [Setting Up Your Printer](#)
  - [Understanding the Software](#)
- 

## Understanding the Printer Parts

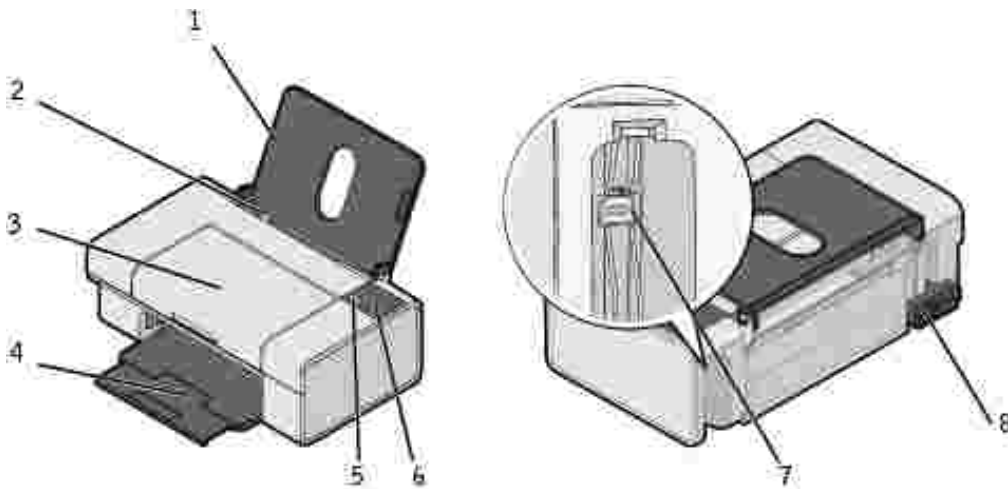

	Part:	Description:
1	Paper support	Part that supports loaded paper.
2	Paper guide	Guide that helps the paper feed into the printer properly.
3	Front cover	Cover you lift to gain access to the ink cartridge or to clear a paper jam.
4	Paper exit tray	Tray that holds the paper as it exits the printer. <b>NOTE:</b> To extend the paper exit tray, pull the tray straight out.
5	Paper feed button	Button you press to feed paper through the printer.
6	Power button	Button you press to power the printer on and off.
7	USB connector	Slot into which you plug the USB cable (sold separately). The other end of the USB cable plugs into your computer.
8	Power connector	Slot into which you plug the power cable. <b>NOTE:</b> Insert the power cable into the printer before connecting the power cable into the wall outlet.

---

## Setting Up Your Printer

 **NOTE:** The Dell™ Color Printer 725 supports Microsoft® Windows® 2000, Windows XP, and Windows XP Professional x64 Edition.

Follow the instructions on your *Setting Up Your Printer* poster to install the hardware and software. If you encounter problems during setup, see [Setup Problems](#).

---

## Understanding the Software

The printer software includes:

- Printing Preferences - Allows you to adjust printer settings.
- Dell Picture Studio™ - Allows you to manage, edit, display, print, and convert photos and other types of images.
- Dell Ink Management System™ - Warns you when your printer is running low on ink.

## Using Printing Preferences



Printing Preferences allows you to change the various printer settings. You can change your printer settings in Printing Preferences depending on the type of project you want to create.

To access Printing Preferences:

1. With your document open, click File→ Print.

The Print dialog box opens.

2. In the Print dialog box, click Preferences, Properties, Options, or Setup (depending on the program or operating system).

The Printing Preferences dialog box opens.

To access Printing Preferences when a document is not open:

1. *In Windows XP*, click Start→ Control Panel→ Printers and Other Hardware→Printers and Faxes.

*In Windows 2000*, click Start→ Settings→ Printers.

2. Right-click the printer icon, and then select Printing Preferences.

The Printing Preferences dialog box opens.

 **NOTE:** Changes made to the printer settings from the Printers folder become the default settings for most programs.

## Printing Preferences Tabs

Tab	Options
Print Setup	Quality/Speed - Select Automatic, Draft, Normal, or Photo depending on your desired output quality.
	Media Type - Allows you to set the paper type.
	Paper Size - Select the size and type of paper.
	Orientation - Select how the document is arranged on the printed page. You can print using portrait or landscape orientation.
	Multiple Copies - Customize how the printer prints several copies of a single print job: Collated, Normal, or Print Last Page First.
Advanced	2-Sided Printing - Select this to print on both sides of the paper.
	Layout - Select Normal, Banner, Mirror, N-up, Poster, Booklet, or Borderless.
	Automatic Image Sharpening - Automatically select the best image sharpening level based on image content.
	More Options - Allows you to specify Appearance Mode options.
Maintenance	Install Print Cartridge
	Clean Print Cartridge
	Align Print Cartridge
	Print a Test Page

## Using Dell Picture Studio

In Dell Picture Studio, you can explore digital photography and learn how to organize, create, or print photos. There are two components to the Dell Picture Studio:

- Paint Shop Photo Album 5

Click Start→ Programs or All Programs→ Dell Picture Studio 3→ Paint Shop Photo Album 5→ Paint Shop Photo Album 5.

- Paint Shop Pro Studio

Click Start→ Programs or All Programs→ Dell Picture Studio 3→ Paint Shop Pro Studio→ Jasc Paint Shop Pro Studio.



**NOTE:** Depending on your operating system, some or all of these programs may not be available to you.

## Dell Ink Management System

Each time you print a job, a printing progress screen appears, which shows the progress of the print job as well as the amount of ink remaining and the approximate number of pages remaining in the cartridge. The page counter is hidden during the first 50 pages of cartridge use, until printing habits are learned and a more accurate count can be given. The number of pages remaining changes as a result of the type of print jobs the printer completes.

When your ink cartridge level is low, a Low Ink Warning appears on your screen when you try to print. This warning is displayed every time you print until you install a new ink cartridge. For more information on replacing an ink cartridge, see [Replacing an Ink Cartridge](#).

When your ink cartridge is empty, the Reserve Tank window appears on your screen when you try to print. If you continue printing, the print job may not print as you expect.

## Removing and Reinstalling the Software

If your printer does not function properly, or communication error messages appear when using your printer, you can remove and reinstall the printer software.

1. Click Start→ Programs or All Programs→ Dell Printers→ Dell Color Printer 725 → Uninstall Dell Color Printer 725.
2. Follow the instructions on the screen.

3. Restart your computer.
4. Insert the *Drivers and Utilities* CD, and then follow the instructions on the screen.

If the installation screen does not appear:

- a. *In Windows XP*, click Start→ My Computer.

*In Windows 2000*, double-click My Computer from your desktop.

- b. Double-click the CD-ROM drive icon. If necessary, double-click setup.exe.
- c. When the printer software installation screen appears, click Personal Installation or Network Installation.
- d. Follow the instructions on your screen to complete the installation.



# Using the Printer

- [Loading Paper](#)
  - [Printing a Document](#)
  - [Printing Photos](#)
  - [Print Borderless Photos](#)
- 

## Loading Paper

1. Fan the paper.



2. Place the paper against the guide on the right side of the paper support.
3. Squeeze and slide the left paper guide to the left edge of the paper.

 **NOTE:** Do not force paper into the printer. The paper should be flat against the paper support surface, and the left edge should be flush against the left paper guide.



---

## Printing a Document

 **NOTE:** The printer only uses a color ink cartridge. However, the printer is still capable of printing in black and white using the color cartridge (Process Black).

1. Turn on your computer and printer, and make sure they are connected.
2. Load paper with the print side facing up. For more information, see [Loading Paper](#).
3. With your document open, click File→ Print.

The Print dialog box opens.

4. To customize your print settings:
  - a. Click Preferences, Properties, Options, or Setup (depending on the program or operating system).

The Printing Preferences dialog box opens.

- b. On the Print Setup tab, select the print quality/speed, paper size, black and white or color printing, borderless printing, orientation, and number of copies.
    - c. On the Advanced tab, you can specify a 2-sided printing option, a specialized layout option, or if you want to use Automatic Image Sharpening.
    - d. Click OK at the bottom of the screen to return to the Print dialog box.
  5. Click OK or Print (depending on the program or operating system).
- 

## Printing Photos

1. Load the photo paper with the print (glossy) side facing up.
2. With your document open, click File→ Print.

The Print dialog box opens.

3. To customize your print settings, click Preferences, Properties, Options, or Setup (depending on the program or operating system).

The Printing Preferences dialog box opens.

 **NOTE:** If you are using the Dell Picture Studio,<sup>™</sup> select View All Printer Settings to view Print Properties.

4. On the Print Setup tab, select Photo, and then select the dpi settings for the photo from the drop-down menu.

5. Select the paper size, orientation, and the number of copies.

 **NOTE:** Photo/glossy paper is recommended for printing photos.

6. When you finish customizing your print settings, click OK.
7. Click OK or Print (depending on the program or operating system).
8. Remove each photo after it exits the paper exit tray to prevent your photos from sticking together or smudging.

 **NOTE:** Before placing your prints in a nonadhesive photo album or frame, allow sufficient time for the prints to dry thoroughly (12 to 24 hours, depending on the ambient conditions). This maximizes the life of your prints.

---

## Print Borderless Photos



1. For best results, load photo/glossy paper, and make sure the print side is facing up.
2. With your document open, click File→ Print.

The Print dialog box opens.

3. To customize your print settings, click Preferences, Properties, Options, or Setup (depending on the program or operating system).

The Printing Preferences dialog box opens.

4. On the Print Setup tab, select Photo, and then select the dpi settings for the photo from the drop-down menu.
5. Select the Borderless check box, orientation of the photo, and the number of copies you want.
6. On the Advanced tab, select the borderless paper size from the drop-down menu, and click OK.

7. Click OK or Print (depending on the program or operating system).

# Ink Cartridge Maintenance

- [Replacing an Ink Cartridge](#)
- [Aligning an Ink Cartridge](#)
- [Cleaning the Ink Cartridge Nozzles](#)

 **CAUTION:** Before performing any of the procedures listed in this section, read and follow the safety information in your *Product Information Guide*.

Dell ink cartridges are only available through Dell. You can order more ink online at [www.dell.com/supplies](http://www.dell.com/supplies) or by phone. To order by phone, see "Ordering Supplies" in your *Owner's Manual*.

Dell recommends Dell ink cartridges for your printer. Dell does not provide warranty coverage for problems caused by using accessories, parts, or components not supplied by Dell.

---

## Replacing an Ink Cartridge

1. Turn on your printer.
2. Lift the front cover.

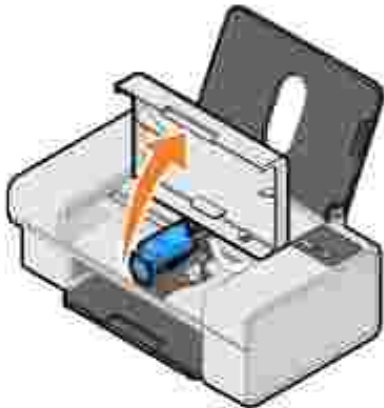

The ink cartridge carrier moves and stops at the loading position unless the printer is busy.

3. Press down on the ink cartridge lever to raise the ink cartridge lid.



4. Remove the old ink cartridge.

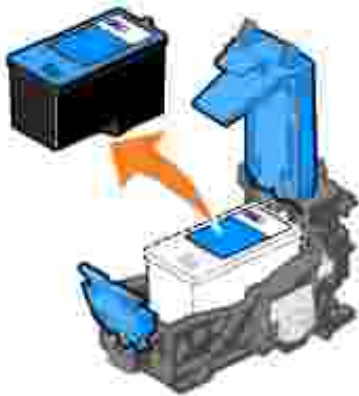

5. Dispose of the old cartridge properly.

6. If you are installing a new ink cartridge, remove the sticker and transparent tape from the back and bottom of the ink cartridge.



7. Insert the new ink cartridge.

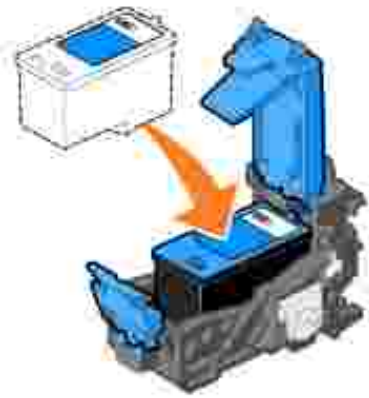

8. *Snap* the lid closed.



9. Close the front cover.



---

## Aligning an Ink Cartridge

Your printer automatically aligns the ink cartridge when it is installed or replaced. You may also need to align the ink cartridge when characters are not properly formed or are not aligned at the left margin, or when vertical or straight lines appear wavy.

To verify your ink cartridge is aligned, you can print an alignment page from the Printing Preferences dialog box.

To align the ink cartridge:

1. Load plain paper. For more information, see [Loading Paper](#).
2. *In Windows XP*, click Start→ Control Panel→ Printers and Other Hardware→ Printers and Faxes.

*In Windows 2000*, click Start→ Settings→ Printers.

3. Right-click the Dell Color Printer 725 icon.
4. Click Printing Preferences.

The Printing Preferences dialog box opens.

5. Click the Maintenance tab.
6. Click Align Print Cartridge.
7. Click Print.

The ink cartridge aligns when the page prints.

---

## Cleaning the Ink Cartridge Nozzles

You may need to clean the nozzles when:

- White lines appear in graphics or solid black areas.
- Print appears smudged or too dark.
- Colors fade, do not print, or do not print completely.
- Vertical lines appear jagged, or edges appear rough.

To clean the ink cartridge nozzles:

1. Load plain paper. For more information, see [Loading Paper](#).
2. *In Windows XP*, click Start→ Control Panel→ Printers and Other Hardware→ Printers and Faxes.



*In Windows 2000*, click Start→ Settings→ Printers.

3. Right-click the Dell Color Printer 725 icon.
4. Click Printing Preferences.

The Printing Preferences dialog box opens.

5. Click the Maintenance tab.
6. Click Clean Print Cartridge.
7. If the print quality has not improved, click Clean Again.
8. Print your document again to verify the improved print quality.
9. If you are still not satisfied with the print quality, wipe the ink cartridge nozzles, and then print your document again.

# Troubleshooting

- [Setup Problems](#)
  - [General Problems](#)
  - [Improving Print Quality](#)
- 

## Setup Problems

### Computer Problems

Verify that your printer is compatible with your computer.

The Dell Color Printer 725 supports Windows 2000, Windows XP, and Windows XP Professional x64 Edition.

Make sure you turned on both your printer and your computer.

Check the USB cable.

- Ensure the USB cable is firmly connected to your printer and your computer.
- Shut down the computer, reconnect the USB cable as shown on the *"Setting Up Your Printer"* poster for your printer, and then restart the computer.

If the software installation screen does not appear automatically, install the software manually.

1. Insert the *Drivers and Utilities* CD.
2. Click Install.

Determine if the printer software is installed.

Click Start→ Programs or All Programs→ Dell Printers→ Dell Color Printer 725. If Dell Color Printer 725 does not appear in the list of programs, the printer software is not installed. Install the printer software. For more information, see [Removing and Reinstalling the Software](#).

Set your printer as the default printer.

1. *In Windows XP*, click Start→ Control Panel→Printers and Other Hardware→ Printers and Faxes.  
  
*In Windows 2000*, click Start→ Settings→ Printers.
2. Right-click Dell Color Printer 725, and select Set as Default.

Correct communication problems between the Printer and the computer.

- Remove the USB cable from your printer and your computer. Reconnect the USB cable to your printer and your computer.
- Turn off the printer. Unplug the printer power cable from the electrical outlet. Reconnect the printer power cable to the electrical outlet, and turn on the printer.
- Restart your computer.

## Printer Problems

Ensure the printer power cable is firmly connected to the printer and the electrical outlet.

Determine if the printer has been held or paused.

1. *In Windows XP*, click Start→ Control Panel→Printers and Other Hardware→ Printers and Faxes.

*In Windows 2000*, click Start→ Settings→ Printers.

2. Double-click Dell Color Printer 725, and then click Printer.
3. Make sure a check mark is not next to Pause Printing. If a check mark is next to Pause Printing, click Pause Printing to clear it.

Check for flashing lights on the printer.

Ensure you installed the ink cartridge correctly and removed the sticker and tape from the cartridge.

Make sure you loaded the paper correctly.

For more information, see [Loading Paper](#).

---

## General Problems

### Paper Problems

Make sure you loaded the paper correctly.

For more information, see [Loading Paper](#).

Use only paper recommended for your printer.

For more information, see [Print Media Guidelines](#).

Use a smaller amount of paper when printing multiple pages.

For more information, see [Print Media Guidelines](#).

Make sure the paper is not wrinkled, torn, or damaged.

Make sure the paper is centered in the paper support, and the paper guides rest against the left and right sides of the paper.

Check for a paper jam.

If the paper jam is located in the paper support:

1. Turn off your printer.
2. Firmly grasp the paper, and gently pull it from the printer.
3. Turn on your printer, and print the document again.

If the paper jam is not visible:

1. Turn off your printer.
  2. Lift the access cover.
  3. Firmly grasp the paper, and gently pull it from the printer.
  4. Close the access cover.
  5. Turn on the printer, and print the document again.
- 

## Improving Print Quality

If you are not satisfied with the print quality of your documents, there are several different ways to improve the print quality.

- Use the appropriate paper. For example, use Dell Premium Photo Paper if you are printing photos.
- Use paper that is a heavier weight, bright white, or coated. Use Dell Premium Photo Paper if you are printing photos.



**NOTE:** Dell Premium Photo Paper may not be available in all areas.

- Select a higher print quality.

To select a higher print quality:

1. With your document open, click File→ Print.

The Print dialog box opens.

2. Click Preferences, Properties, or Options (depending on your program or operating system).

The Printing Preferences dialog box opens.

3. On the Print Setup tab, select a higher quality setting.
4. Print your document again.
5. If the print quality does not improve, try aligning or cleaning the ink cartridge. For more information on aligning the ink cartridge, see [Aligning an Ink Cartridge](#). For more information on cleaning the ink cartridge, see [Cleaning the Ink Cartridge Nozzles](#).

For additional solutions, go to [support.dell.com](http://support.dell.com).

# Printer Specifications

- [Overview](#)
  - [Environmental Specifications](#)
  - [Power Consumption and Requirements](#)
  - [Print Capabilities](#)
  - [Operating System Support](#)
  - [System Specifications and Requirements](#)
  - [Print Media Guidelines](#)
  - [Cables](#)
- 

## Overview

SDRAM	2 MB
Connectivity	USB 2.0 (full speed)
Duty cycle (maximum)	1,000 pages/month
Printer life	12,000 pages

---

## Environmental Specifications

### Temperature/Relative Humidity

Condition	Temperature	Relative humidity (non-condensing)
Operation	15° to 32° C (60° to 90° F)	40 to 80%
Storage	1° to 60° C (34° to 140° F)	5 to 80%
Shipping	-40° to 65° C (-40° to 149° F)	5 to 100%

---

## Power Consumption and Requirements

Rated AC Input	100–240 VAC
Rated Frequency	50/60 Hz
Minimum AC input	90 VAC
Maximum AC input	255 VAC
Maximum input current	1.0 A
Average power consumption	
Standby mode	2 W
Operational mode	10 W

## Print Capabilities

Your Dell Color Printer 725 can print with the following resolutions.

### Photo/Glossy Media

Quality	Print resolution
Quick	600 x 600 dpi
Normal	1200 x 1200 dpi
Photo	4800 x 1200 dpi

### All Other Media

Quality	Print resolution
Quick	300 x 600 dpi
Normal	600 x 600 dpi
Photo	1200 x 1200 dpi

## Operating System Support

The Dell Color Printer 725 supports:

- Windows XP Professional x64 Edition

- Windows XP

## System Specifications and Requirements

Your operating system must meet the minimum system requirements.

Operating system	Processor	RAM (MB)	Hard disk (MB)
Windows XP Professional x64 Edition	AMD Athlon 64, AMD Opteron, Intel Xeon with Intel EM64T support, or Intel Pentium 4 with Intel EM64T support	256	500
Windows XP	Pentium 300	128	500
Windows 2000	Pentium 233	128	500

## Print Media Guidelines

Load up to:	Make sure:
100 sheets of plain paper	<ul style="list-style-type: none"> <li>The paper is loaded vertically against the right side of the paper support.</li> <li>The paper guide rests against the left edge of the paper.</li> </ul>  <p><b>NOTE:</b> Load letterhead paper with the top of the letterhead entering the printer first and facing up.</p>
20 sheets of banner paper	<ul style="list-style-type: none"> <li>You remove any paper from the paper support before inserting banner paper.</li> <li>You place a stack of banner paper on or behind the printer, with only the number of sheets required.</li> </ul>

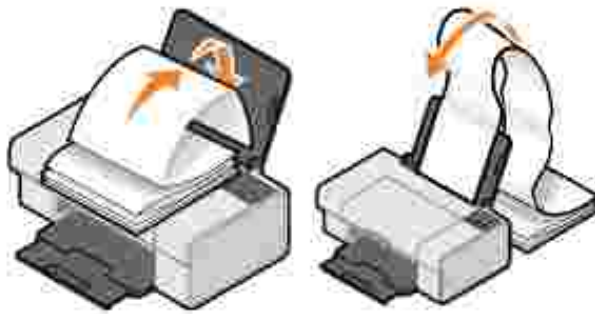

**NOTE:** You must select A4 Banner or Letter Banner paper size in Print Properties. Failure to do so will cause a paper jam. See [Paper Problems](#).

- You load the leading edge of the banner paper into the printer against the right side of the paper support.
- You squeeze and slide the paper guide to the left edge of the banner paper.
- You use banner paper designed for inkjet printers.

10 envelopes

- The print side of the envelopes faces up.
- The envelopes are loaded vertically against the right side of the paper support.
- The stamp location is in the upper left corner and printed with landscape orientation.



**NOTE:** For Japanese customers: If you are mailing within Japan, the envelope can be printed with portrait orientation with the stamp in the lower right corner or with landscape orientation with the stamp in the lower left corner. If you are mailing internationally, print landscape orientation with the stamp in the upper left corner.

- The paper guide rests against the left edge of the envelopes.
- You select the correct envelope size. Select the next biggest size if the exact envelope size is not listed, and set the left and right margins so that your envelope text will be correctly positioned.

25 greeting cards, index cards, postcards, or photo cards

- The print side of the cards faces up.
- The cards are loaded vertically against the right side of the paper support.
- The paper guide rests against the left edge of the cards.
- You select Normal or Photo print quality.

50 sheets of photo or glossy paper

- The glossy side of the paper faces up.
- The paper guide rests against the left edge of the paper.
- You select Normal or Photo print quality.
- The paper is loaded vertically against the right side of the paper support.



10 iron-on transfers	<ul style="list-style-type: none"><li>• You follow the loading instructions on the packaging.</li><li>• The blank side of the transfer faces up.</li><li>• The paper guide rests against the left edge of the transfer.</li><li>• You select Normal or Photo print quality.</li></ul> <p><b>NOTE:</b> For best results, iron-on transfers should be fed one sheet at a time.</p>
50 transparencies	<ul style="list-style-type: none"><li>• The rough side of the transparencies faces up.</li><li>• The paper guide rests against the left edge of the transparencies.</li></ul> <p><b>NOTE:</b> You can load a single transparency into the paper support without removing plain paper.</p> <ul style="list-style-type: none"><li>• You select Normal or Photo print quality.</li></ul>

## Cables

Your Dell Color Printer 725 uses a Universal Serial Bus (USB) cable (sold separately).



# Ordering Supplies

Your Dell Color Printer 725 includes software installed to detect the ink levels in the printer. During a print job, a screen appears on your computer to warn you of low ink levels. You can order ink online at [www.dell.com/supplies](http://www.dell.com/supplies) or by phone.

US	877-INK-2-YOU	Korea	080-999-0240
Australia	1300 303 290	Luxembourg	02.713 1590
Austria	08 20 - 24 05 30 35	Malaysia	1800 88 0553
Belgium	02.713 1590	Mexico	001 866 851 1754
Canada	877-501-4803	Netherlands	020 - 674 4881
Chile	1230-020-3947	Norway	231622 64
	800-202874	Portugal	21 4220710
Colombia	01800-9-155676	PRC	800-858-2425
Czech	+420 225 372 711	Poland	022 579 59 65
Denmark	3287 5215	Puerto Rico	866-851-1760
Finland	09 2533 1411	Singapore	1800 394 7245
France	825387247	South Africa	0860 102 591
Germany	0800 2873355	Spain	902120385
Ireland	1850 707 407	Sweden	08 587 705 81
Italy	800602705	Switzerland	0848 335 599
Japan	044-556-3551	UK	0870 907 4574



**NOTE:** If your country is not listed, contact your Dell distributor to order supplies.

Your printer has been designed to print using the following ink cartridges.

Supply Item	Part number
Standard Capacity color ink cartridge	JF333

# Contacting Dell

- [Technical Assistance](#)
  - [Automated Order-Status Service](#)
  - [Contacting Dell](#)
- 

## Technical Assistance

If you need help with a technical problem, Dell is ready to assist you.

1. Call technical support from a telephone near or at the printer so that technical support can assist you with any necessary procedures. When calling Dell, use your Express Service Code to help expedite the routing of your call to the proper support personnel.

The Express Service Code is located under the front cover.

NOTE: Dell's Express Service Code system may not be available in all countries.

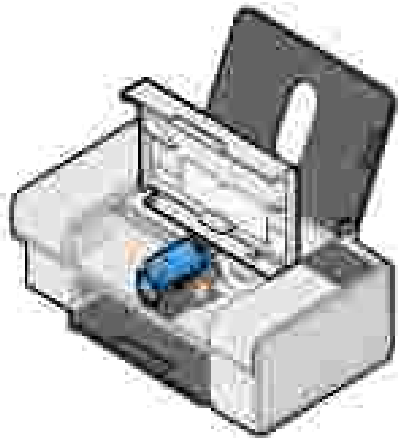

2. In the U.S., Business customers should call 1-877-459-7298, and Consumer (Home and Home Office) customers should call 1-800-624-9896.

If you are calling from a different country or are in a different Service area, see [Contacting Dell](#) for your local telephone number.

3. Follow the menu prompts in the automated telephone system to speak with a technical support representative.
- 

## Automated Order-Status Service

To check on the status of any Dell products that you have ordered, you can go to [support.dell.com](http://support.dell.com), or you can call the automated order-status service. A recording prompts you for the information needed to locate and report on your order. See [Contacting Dell](#) for the telephone number to call for your region.

## Contacting Dell

To contact Dell electronically, you can access the following websites:

- [www.dell.com](http://www.dell.com)
- [support.dell.com](http://support.dell.com) (technical support)
- [premiersupport.dell.com](http://premiersupport.dell.com) (technical support for educational, government, healthcare, and medium/large business customers, including Premier, Platinum, and Gold customers)

For specific web addresses for your country, find the appropriate country section in the table below.

NOTE: Toll-free numbers are for use within the country for which they are listed.

NOTE: In certain countries, technical support specific to Dell XPS portable computers is available at a separate telephone number listed for participating countries. If you do not see a telephone number listed that is specific for XPS portable computers, you may contact Dell through the technical support number listed and your call will be routed appropriately.

When you need to contact Dell, use the electronic addresses, telephone numbers, and codes provided in the following table. If you need assistance in determining which codes to use, contact a local or an international operator.

Country (City) International Access Code Country Code City Code	Department Name or Service Area, Website and E-Mail Address	Area Codes, Local Numbers, and Toll-Free Numbers
Anguilla	General Support	toll-free: 800-335-0031
Antigua and Barbuda	General Support	1-800-805-5924
Argentina (Buenos Aires)  International Access Code: 00  Country Code: 54  City Code: 11	Website: <a href="http://www.dell.com.ar">www.dell.com.ar</a>	
	E-mail: <a href="mailto:us_latin_services@dell.com">us_latin_services@dell.com</a>	
	E-mail for desktop and portable computers: <a href="mailto:la-techsupport@dell.com">la-techsupport@dell.com</a>	
	E-mail for servers and EMC® storage products: <a href="mailto:la_enterprise@dell.com">la_enterprise@dell.com</a>	
	Customer Care	toll-free: 0-800-444-0730
	Tech Support	toll-free: 0-800-444-0733

	Tech Support Services	toll-free: 0-800-444-0724
	Sales	0-810-444-3355
Aruba	General Support	toll-free: 800-1578
Australia (Sydney)	E-mail (Australia): au_tech_support@dell.com	
International Access Code: 0011	E-mail Customer Care (Australia and New Zealand): apcustserv@dell.com	
Country Code: 61	Home and Small Business	1-300-655-533
City Code: 2	Government and Business	toll-free: 1-800-633-559
	Preferred Accounts Division (PAD)	toll-free: 1-800-060-889
	Customer Care (after sales)	toll-free: 1-333-55 (option 3)
	Technical Support (portables and desktops)	toll-free: 1-300-655-533
	Technical Support (servers and workstations)	toll-free: 1-800-733-314
	Corporate Sales	toll-free: 1-800-808-385
	Transaction Sales	toll-free: 1-800-808-312
	Fax	toll-free: 1-800-818-341
Austria (Vienna)	Website: support.euro.dell.com	
International Access Code: 900	E-mail: tech_support_central_europe@dell.com	
Country Code: 43	Home/Small Business Sales	0820 240 530 00
City Code: 1	Home/Small Business Fax	0820 240 530 49
	Home/Small Business Customer Care	0820 240 530 14
	Preferred Accounts/Corporate Customer Care	0820 240 530 16
	Technical Support for XPS portable computers only	0820 240 530 81
	Home/Small Business Technical Support for all other Dell computers	0820 240 530 14
	Preferred Accounts/Corporate Technical Support	0660 8779
	Switchboard	0820 240 530 00
Bahamas	General Support	toll-free: 1-866-278-6818
Barbados	General Support	1-800-534-3066
Belgium (Brussels)	Website: support.euro.dell.com	
International Access Code: 00	E-mail for French-speaking Customers: support.euro.dell.com/be/fr/emaildell/	
Country Code: 32	Technical Support for XPS portable computers only	02 481 92 96
City Code: 2	Technical Support for all other Dell computers	02 481 92 88
	Technical Support Fax	02 481 92 95
	Customer Care	02 713 15 65

	Corporate Sales	02 481 91 00
	Fax	02 481 92 99
	Switchboard	02 481 91 00
Bermuda	General Support	1-800-342-0671
Bolivia	General Support	toll-free: 800-10-0238
Brazil	Website: <a href="http://www.dell.com/br">www.dell.com/br</a>	
International Access Code: 00	Customer Support, Technical Support	0800 90 3355
Country Code: 55	Technical Support Fax	51 481 5470
City Code: 51	Customer Care Fax	51 481 5480
	Sales	0800 90 3390
British Virgin Islands	General Support	toll-free: 1-866-278-6820
Brunei	Customer Technical Support (Penang, Malaysia)	604 633 4966
Country Code: 673	Customer Care (Penang, Malaysia)	604 633 4888
	Transaction Sales (Penang, Malaysia)	604 633 4955
Canada (North York, Ontario)	Online Order Status: <a href="http://www.dell.ca/ostatus">www.dell.ca/ostatus</a>	
International Access Code: 011	AutoTech (automated technical support)	toll-free: 1-800-247-9362
	Customer Care (Home Sales/Small Business)	toll-free: 1-800-847-4096
	Customer Care (med./large business, government)	toll-free: 1-800-326-9463
	Technical Support (Home Sales/Small Business)	toll-free: 1-800-847-4096
	Technical Support (med./large bus., government)	toll-free: 1-800-387-5757
	Technical Support (printers, projectors, televisions, handhelds, digital jukebox, and wireless)	1-877-335-5767
	Sales (Home Sales/Small Business)	toll-free: 1-800-387-5752
	Sales (med./large bus., government)	toll-free: 1-800-387-5755
	Spare Parts Sales & Extended Service Sales	1 866 440 3355
Cayman Islands	General Support	1-800-805-7541
Chile (Santiago)	Sales, Customer Support, and Technical Support	toll-free: 1230-020-4823
Country Code: 56		
City Code: 2		
China (Xiamen)	Technical Support website: <a href="http://support.dell.com.cn">support.dell.com.cn</a>	
Country Code: 86	Technical Support E-mail: <a href="mailto:cn_support@dell.com">cn_support@dell.com</a>	
City Code: 592	Customer Care E-mail: <a href="mailto:customer_cn@dell.com">customer_cn@dell.com</a>	
	Technical Support Fax	592 818 1350
	Technical Support (Dell™ Dimension™ and Inspiron)	toll-free: 800 858 2969

	Technical Support (OptiPlex™, Latitude™, and Dell Precision™)	toll-free: 800 858 0950
	Technical Support (servers and storage)	toll-free: 800 858 0960
	Technical Support (projectors, PDAs, switches, routers, and so on)	toll-free: 800 858 2920
	Technical Support (printers)	toll-free: 800 858 2311
	Customer Care	toll-free: 800 858 2060
	Customer Care Fax	592 818 1308
	Home and Small Business	toll-free: 800 858 2222
	Preferred Accounts Division	toll-free: 800 858 2557
	Large Corporate Accounts GCP	toll-free: 800 858 2055
	Large Corporate Accounts Key Accounts	toll-free: 800 858 2628
	Large Corporate Accounts North	toll-free: 800 858 2999
	Large Corporate Accounts North Government and Education	toll-free: 800 858 2955
	Large Corporate Accounts East	toll-free: 800 858 2020
	Large Corporate Accounts East Government and Education	toll-free: 800 858 2669
	Large Corporate Accounts Queue Team	toll-free: 800 858 2572
	Large Corporate Accounts South	toll-free: 800 858 2355
	Large Corporate Accounts West	toll-free: 800 858 2811
	Large Corporate Accounts Spare Parts	toll-free: 800 858 2621
Colombia	General Support	980-9-15-3978
Costa Rica	General Support	0800-012-0435
Czech Republic (Prague)  International Access Code: 00  Country Code: 420	Website: support.euro.dell.com	
	E-mail: czech_dell@dell.com	
	Technical Support	22537 2727
	Customer Care	22537 2707
	Fax	22537 2714
	Tech Fax	22537 2728
	Switchboard	22537 2711
Denmark (Copenhagen)  International Access Code: 00  Country Code: 45	Website: support.euro.dell.com	
	E-mail: support.euro.dell.com/dk/da/emaildell/	
	Technical Support for XPS portable computers only	7010 0074
	Technical Support for all other Dell computers	7023 0182
	Customer Care (Relational)	7023 0184



	Home/Small Business Customer Care	3287 5505
	Switchboard (Relational)	3287 1200
	Switchboard Fax (Relational)	3287 1201
	Switchboard (Home/Small Business)	3287 5000
	Switchboard Fax (Home/Small Business)	3287 5001
Dominica	General Support	toll-free: 1-866-278-6821
Dominican Republic	General Support	1-800-148-0530
Ecuador	General Support	toll-free: 999-119
El Salvador	General Support	01-899-753-0777
Finland (Helsinki)	Website: support.euro.dell.com	
International Access Code: 990	E-mail: support.euro.dell.com/fi/fi/emaildell/	
Country Code: 358	Technical Support	09 253 313 60
City Code: 9	Customer Care	09 253 313 38
	Fax	09 253 313 99
	Switchboard	09 253 313 00
France (Paris) (Montpellier)	Website: support.euro.dell.com	
International Access Code: 00	E-mail: support.euro.dell.com/fr/fr/emaildell/	
Country Code: 33	Home and Small Business	
City Codes: (1) (4)	Technical Support for XPS portable computers only	0825 387 129
	Technical Support for all other Dell computers	0825 387 270
	Customer Care	0825 823 833
	Switchboard	0825 004 700
	Switchboard (calls from outside of France)	04 99 75 40 00
	Sales	0825 004 700
	Fax	0825 004 701
	Fax (calls from outside of France)	04 99 75 40 01
	Corporate	
	Technical Support	0825 004 719
	Customer Care	0825 338 339
	Switchboard	01 55 94 71 00
	Sales	01 55 94 71 00
	Fax	01 55 94 71 01
Germany (Langen)	Website: support.euro.dell.com	
International Access	E-mail: tech_support_central_europe@dell.com	

Code: 00	Technical Support for XPS portable computers only	06103 766-7222
Country Code: 49	Technical Support for all other Dell computers	06103 766-7200
City Code: 6103	Home/Small Business Customer Care	0180-5-224400
	Global Segment Customer Care	06103 766-9570
	Preferred Accounts Customer Care	06103 766-9420
	Large Accounts Customer Care	06103 766-9560
	Public Accounts Customer Care	06103 766-9555
	Switchboard	06103 766-7000
	Greece	Website: support.euro.dell.com
International Access Code: 00	E-mail: support.euro.dell.com/gr/en/emaildell/	
	Technical Support	00800-44 14 95 18
Country Code: 30	Gold Service Technical Support	00800-44 14 00 83
	Switchboard	2108129810
	Gold Service Switchboard	2108129811
	Sales	2108129800
	Fax	2108129812
Grenada	General Support	toll-free: 1-866-540-3355
Guatemala	General Support	1-800-999-0136
Guyana	General Support	toll-free: 1-877-270-4609
Hong Kong	Website: support.ap.dell.com	
International Access Code: 001	Technical Support E-mail: apsupport@dell.com	
	Technical Support (Dimension and Inspiron)	2969 3188
Country Code: 852	Technical Support (OptiPlex, Latitude, and Dell Precision)	2969 3191
	Technical Support (PowerApp™, PowerEdge™, PowerConnect™, and PowerVault™)	2969 3196
	Customer Care	3416 0910
	Large Corporate Accounts	3416 0907
	Global Customer Programs	3416 0908
	Medium Business Division	3416 0912
	Home and Small Business Division	2969 3105
India	E-mail: india_support_desktop@dell.com india_support_notebook@dell.com india_support_Server@dell.com	
	Technical Support	1600 33 8045 and 1600 44 8046

	Sales (Large Corporate Accounts)	1600 33 8044
	Sales (Home and Small Business)	1600 33 8046
Ireland (Cherrywood)  International Access Code: 16  Country Code: 353  City Code: 1	Website: support.euro.dell.com	
	E-mail: dell_direct_support@dell.com	
	Technical Support for XPS portable computers only	1850 200 722
	Technical Support for all other Dell computers	1850 543 543
	U.K. Technical Support (dial within U.K. only)	0870 908 0800
	Home User Customer Care	01 204 4014
	Small Business Customer Care	01 204 4014
	U.K. Customer Care (dial within U.K. only)	0870 906 0010
	Corporate Customer Care	1850 200 982
	Corporate Customer Care (dial within U.K. only)	0870 907 4499
	Ireland Sales	01 204 4444
	U.K. Sales (dial within U.K. only)	0870 907 4000
	Fax/Sales Fax	01 204 0103
	Switchboard	01 204 4444
	Italy (Milan)  International Access Code: 00  Country Code: 39  City Code: 02	Website: support.euro.dell.com
E-mail: support.euro.dell.com/it/it/emaildell/		
Home and Small Business		
Technical Support		02 577 826 90
Customer Care		02 696 821 14
Fax		02 696 821 13
Switchboard		02 696 821 12
Corporate		
Technical Support		02 577 826 90
Customer Care		02 577 825 55
Fax		02 575 035 30
Switchboard	02 577 821	
Jamaica	General Support (dial from within Jamaica only)	1-800-682-3639
Japan (Kawasaki)  International Access Code: 001  Country Code: 81  City Code: 44	Website: support.jp.dell.com	
	Technical Support (servers)	toll-free: 0120-198-498
	Technical Support outside of Japan (servers)	81-44-556-4162
	Technical Support (Dimension and Inspiron)	toll-free: 0120-198-226
	Technical Support outside of Japan (Dimension and Inspiron)	81-44-520-1435

	Technical Support (Dell Precision, OptiPlex, and Latitude)	toll-free: 0120-198-433
	Technical Support outside of Japan (Dell Precision, OptiPlex, and Latitude)	81-44-556-3894
	Technical Support (PDAs, projectors, printers, routers)	toll-free: 0120-981-690
	Technical Support outside of Japan (PDAs, projectors, printers, routers)	81-44-556-3468
	Faxbox Service	044-556-3490
	24-Hour Automated Order Service	044-556-3801
	Customer Care	044-556-4240
	Business Sales Division (up to 400 employees)	044-556-1465
	Preferred Accounts Division Sales (over 400 employees)	044-556-3433
	Large Corporate Accounts Sales (over 3500 employees)	044-556-3430
	Public Sales (government agencies, educational institutions, and medical institutions)	044-556-1469
	Global Segment Japan	044-556-3469
	Individual User	044-556-1760
	Switchboard	044-556-4300
Korea (Seoul)	E-mail: <a href="mailto:krsupport@dell.com">krsupport@dell.com</a>	
International Access Code: 001	Technical Support	toll-free: 080-200-3800
Country Code: 82	Technical Support (Dimension, PDA, Electronics, and Accessories)	toll-free: 080-200-3801
City Code: 2	Sales	toll-free: 080-200-3600
	Fax	2194-6202
	Switchboard	2194-6000
Latin America	Customer Technical Support (Austin, Texas, U.S.A.)	512 728-4093
	Customer Service (Austin, Texas, U.S.A.)	512 728-3619
	Fax (Technical Support and Customer Service) (Austin, Texas, U.S.A.)	512 728-3883
	Sales (Austin, Texas, U.S.A.)	512 728-4397
	SalesFax (Austin, Texas, U.S.A.)	512 728-4600 or 512 728-3772
Luxembourg	Website: <a href="http://support.euro.dell.com">support.euro.dell.com</a>	
International Access Code: 00	Technical Support	342 08 08 075
	Home/Small Business Sales	+32 (0)2 713 15 96

Country Code: 352	Corporate Sales	26 25 77 81
	Customer Care	+32 (0)2 481 91 19
	Fax	26 25 77 82
Macao	Technical Support	toll-free: 0800 105
Country Code: 853	Customer Service (Xiamen, China)	34 160 910
	Transaction Sales (Xiamen, China)	29 693 115
Malaysia (Penang)	Website: support.ap.dell.com	
International Access Code: 00 Country Code: 60 City Code: 4	Technical Support (Dell Precision, OptiPlex, and Latitude)	toll-free: 1 800 880 193
	Technical Support (Dimension, Inspiron, and Electronics and Accessories)	toll-free: 1 800 881 306
	Technical Support (PowerApp, PowerEdge, PowerConnect, and PowerVault)	toll-free: 1800 881 386
	Customer Care	toll-free: 1800 881 306 (option 6)
	Transaction Sales	toll-free: 1 800 888 202
	Corporate Sales	toll-free: 1 800 888 213
	Mexico	Customer Technical Support
International Access Code: 00 Country Code: 52	Sales	50-81-8800 or 01-800-888-3355
	Customer Service	001-877-384-8979 or 001-877-269-3383
	Main	50-81-8800 or 01-800-888-3355
Montserrat	General Support	toll-free: 1-866-278-6822
Netherlands Antilles	General Support	001-800-882-1519
Netherlands (Amsterdam) International Access Code: 00 Country Code: 31 City Code: 20	Website: support.euro.dell.com	
	Technical Support for XPS portable computers only	020 674 45 94
	Technical Support for all other Dell computers	020 674 45 00
	Technical Support Fax	020 674 47 66
	Home/Small Business Customer Care	020 674 42 00
	Relational Customer Care	020 674 43 25
	Home/Small Business Sales	020 674 55 00
	Relational Sales	020 674 50 00

	Home/Small Business Sales Fax	020 674 47 75
	Relational Sales Fax	020 674 47 50
	Switchboard	020 674 50 00
	Switchboard Fax	020 674 47 50
New Zealand	E-mail (New Zealand): nz_tech_support@dell.com	
International Access Code: 00	E-mail Customer Care (Australia and New Zealand): apcustserv@dell.com	
Country Code: 64	Customer Care	toll-free: 0800 289 335 (option 3)
	Technical Support (for desktop and portable computers)	toll-free: 0800 446 255
	Technical Support (for servers and workstations)	toll-free: 0800 443 563
	Home and Small Business	0800 446 255
	Government and Business	0800 444 617
	Sales	0800 441 567
	Fax	0800 441 566
Nicaragua	General Support	001-800-220-1006
Norway (Lysaker)	Website: support.euro.dell.com	
International Access Code: 00	E-mail: support.euro.dell.com/no/no/emaildell/	
Country Code: 47	Technical Support for XPS portable computers only	815 35 043
	Technical Support for all other Dell products	671 16882
	Relational Customer Care	671 17575
	Home/Small Business Customer Care	231 62298
	Switchboard	671 16800
	Fax Switchboard	671 16865
Panama	General Support	001-800-507-0962
Peru	General Support	0800-50-669
Poland (Warsaw)	Website: support.euro.dell.com	
International Access Code: 011	E-mail: pl_support_tech@dell.com	
Country Code: 48	Customer Service Phone	57 95 700
City Code: 22	Customer Care	57 95 999
	Sales	57 95 999
	Customer Service Fax	57 95 806
	Reception Desk Fax	57 95 998
	Switchboard	57 95 999
Portugal	Website: support.euro.dell.com	

International Access Code: 00 Country Code: 351	E-mail: support.euro.dell.com/pt/en/emaildell/	
	Technical Support	707200149
	Customer Care	800 300 413
	Sales	800 300 410 or 800 300 411 or 800 300 412 or 21 422 07 10
	Fax	21 424 01 12
Puerto Rico	General Support	1-800-805-7545
St. Kitts and Nevis	General Support	toll-free: 1-877-441-4731
St. Lucia	General Support	1-800-882-1521
St. Vincent and the Grenadines	General Support	toll-free: 1-877-270-4609
Singapore (Singapore) International Access Code: 005 Country Code: 65	Website: support.ap.dell.com	
	Technical Support (Dimension, Inspiron, and Electronics and Accessories)	toll-free: 1800 394 7430
	Technical Support (OptiPlex, Latitude, and Dell Precision)	toll-free: 1800 394 7488
	Technical Support (PowerApp, PowerEdge, PowerConnect, and PowerVault)	toll-free: 1800 394 7478
	Customer Service	toll-free: 1800 394 7430 (option 6)
	Transaction Sales	toll-free: 1800 394 7412
	Corporate Sales	toll-free: 1800 394 7419
Slovakia (Prague) International Access Code: 00 Country Code: 421	Website: support.euro.dell.com	
	E-mail: czech_dell@dell.com	
	Technical Support	02 5441 5727
	Customer Care	420 22537 2707
	Fax	02 5441 8328
	Tech Fax	02 5441 8328
	Switchboard (Sales)	02 5441 7585
South Africa (Johannesburg) International Access Code: 09/091 Country Code: 27 City Code: 11	Website: support.euro.dell.com	
	E-mail: dell_za_support@dell.com	
	Gold Queue	011 709 7713
	Technical Support	011 709 7710
	Customer Care	011 709 7707
	Sales	011 709 7700
	Fax	011 706 0495

	Switchboard	011 709 7700
Southeast Asian and Pacific Countries	Customer Technical Support, Customer Service, and Sales (Penang, Malaysia)	604 633 4810
Spain (Madrid)	Website: support.euro.dell.com	
International Access Code: 00	E-mail: support.euro.dell.com/es/es/emaildell/	
Country Code: 34	Home and Small Business	
City Code: 91	Technical Support	902 100 130
	Customer Care	902 118 540
	Sales	902 118 541
	Switchboard	902 118 541
	Fax	902 118 539
	Corporate	
	Technical Support	902 100 130
	Customer Care	902 115 236
	Switchboard	91 722 92 00
	Fax	91 722 95 83
Sweden (Upplands Vasby)	Website: support.euro.dell.com	
International Access Code: 00	E-mail: support.euro.dell.com/se/sv/emaildell/	
Country Code: 46	Technical Support for XPS portable computers only	0771 340 340
City Code: 8	Technical Support for all other Dell products	08 590 05 199
	Relational Customer Care	08 590 05 642
	Home/Small Business Customer Care	08 587 70 527
	Employee Purchase Program (EPP) Support	20 140 14 44
	Technical Support Fax	08 590 05 594
	Sales	08 590 05 185
Switzerland (Geneva)	Website: support.euro.dell.com	
International Access Code: 00	E-mail: Tech_support_central_Europe@dell.com	
Country Code: 41	E-mail for French-speaking HSB and Corporate Customers: support.euro.dell.com/ch/fr/emaildell/	
City Code: 22	Technical Support for XPS portable computers only	0848 33 88 57
	Technical Support (Home and Small Business) for all other Dell products	0844 811 411
	Technical Support (Corporate)	0844 822 844
	Customer Care (Home and Small Business)	0848 802 202



	Customer Care (Corporate)	0848 821 721
	Fax	022 799 01 90
	Switchboard	022 799 01 01
Taiwan	Website: support.ap.dell.com	
International Access Code: 002	E-mail: ap_support@dell.com	
Country Code: 886	Technical Support (OptiPlex, Latitude, Inspiron, Dimension, and Electronics and Accessories)	toll-free: 00801 86 1011
	Technical Support (PowerApp, PowerEdge, PowerConnect, and PowerVault)	toll-free: 00801 60 1256
	Customer Care	toll-free: 00801 60 1250 (option 5)
	Transaction Sales	toll-free: 00801 65 1228
	Corporate Sales	toll-free: 00801 65 1227
Thailand	Website: support.ap.dell.com	
International Access Code: 001	Technical Support (OptiPlex, Latitude, and Dell Precision)	toll-free: 1800 0060 07
Country Code: 66	Technical Support (PowerApp, PowerEdge, PowerConnect, and PowerVault)	toll-free: 1800 0600 09
	Customer Care	toll-free: 1800 006 007 (option 7)
	Corporate Sales	toll-free: 1800 006 009
	Transaction Sales	toll-free: 1800 006 006
Trinidad/Tobago	General Support	1-800-805-8035
Turks and Caicos Islands	General Support	toll-free: 1-866-540-3355
U.K. (Bracknell)	Website: support.euro.dell.com	
International Access Code: 00	Customer Care website: support.euro.dell.com/uk/en/ECare/Form/Home.asp	
Country Code: 44	E-mail: dell_direct_support@dell.com	
City Code: 1344	Technical Support (Corporate/Preferred Accounts/PAD [1000+ employees])	0870 908 0500
	Technical Support for XPS portable computers only	0870 366 4180
	Technical Support (direct and general) for all other products	0870 908 0800
	Global Accounts Customer Care	01344 373 186
	Home and Small Business Customer Care	0870 906 0010
	Corporate Customer Care	01344 373 185

	Preferred Accounts (500–5000 employees) Customer Care	0870 906 0010
	Central Government Customer Care	01344 373 193
	Local Government & Education Customer Care	01344 373 199
	Health Customer Care	01344 373 194
	Home and Small Business Sales	0870 907 4000
	Corporate/Public Sector Sales	01344 860 456
	Home and Small Business Fax	0870 907 4006
Uruguay	General Support	toll-free: 000-413-598-2521
U.S.A. (Austin, Texas) International Access Code: 011 Country Code: 1	Automated Order-Status Service	toll-free: 1-800-433-9014
	AutoTech (portable and desktop computers)	toll-free: 1-800-247-9362
	Technical Support (Dell TV, Printers, and Projectors) for Relationship customers	toll-free 1-877-459-7298
	Consumer (Home and Home Office)	
	Technical Support for all other Dell products	toll-free: 1-800-624-9896
	Customer Service	toll-free: 1-800-624-9897
	DellNet™ Service and Support	toll-free: 1-877-Dellnet (1-877-335-5638)
	Employee Purchase Program (EPP) Customers	toll-free: 1-800-695-8133
	Financial Services website: <a href="http://www.dellfinancialservices.com">www.dellfinancialservices.com</a>	
	Financial Services (lease/loans)	toll-free: 1-877-577-3355
	Financial Services (Dell Preferred Accounts [DPA])	toll-free: 1-800-283-2210
	Business	
	Customer Service and Technical Support	toll-free: 1-800-456-3355
	Employee Purchase Program (EPP) Customers	toll-free: 1-800-695-8133
	Printers and Projectors Technical Support	toll-free: 1-877-459-7298
	Public (government, education, and healthcare)	
	Customer Service and Technical Support	toll-free: 1-800-456-3355
	Employee Purchase Program (EPP) Customers	toll-free: 1-800-695-8133
	Dell Sales	toll-free: 1-800-289-3355 or toll-free: 1-800-879-3355
	Dell Outlet Store (Dell refurbished computers)	toll-free: 1-888-798-7561
Software and Peripherals Sales	toll-free: 1-800-671-3355	
Spare Parts Sales	toll-free: 1-800-357-3355	

	Extended Service and Warranty Sales	toll-free: 1-800-247-4618
	Fax	toll-free: 1-800-727-8320
	Dell Services for the Deaf, Hard-of-Hearing, or Speech-Impaired	toll-free: 1-877-DELLTTY (1-877-335-5889)
U.S. Virgin Islands	General Support	1-877-673-3355
Venezuela	General Support	8001-3605

# Regulatory Notices

- [FCC Notices \(U.S. Only\)](#)
- [Industry Canada \(Canada Only\)](#)
- [CE Notice \(European Union\)](#)
- [VCCI Notice \(Japan Only\)](#)
- [MIC Notice \(Republic of Korea Only\)](#)
- [NOM Information \(Mexico Only\)](#)
- [ENERGY STAR® Compliance](#)
- [ENERGY STAR® Emblem](#)
- [Waste Electrical and Electronic Equipment \(WEEE\) Directive](#)

Electromagnetic Interference (EMI) is any signal or emission, radiated in free space or conducted along power or signal leads, that endangers the functioning of radio navigation or other safety service or seriously degrades, obstructs, or repeatedly interrupts a licensed radio communications service. Radio communications services include but are not limited to AM/FM commercial broadcast, television, cellular services, radar, air-traffic control, pager, and Personal Communication Services (PCS). These licensed services, along with unintentional radiators such as digital devices, including computer systems, contribute to the electromagnetic environment.

Electromagnetic Compatibility (EMC) is the ability of items of electronic equipment to function properly together in the electronic environment. While this computer system has been designed and determined to be compliant with regulatory agency limits for EMI, there is no guarantee that interference will not occur in a particular installation. If this equipment does cause interference with radio communications services, which can be determined by turning the equipment off and on, you are encouraged to try to correct the interference by one or more of the following measures:

- Reorient the receiving antenna.
- Relocate the device with respect to the receiver.
- Move the device away from the receiver.
- Plug the device into a different outlet so that the device and the receiver are on different branch circuits.

If necessary, consult a Dell Technical Support representative or an experienced radio/television technician for additional suggestions.

Dell printers are designed, tested, and classified for their intended electromagnetic environment. These electromagnetic environment classifications generally refer to the following harmonized definitions:

- Class A is typically for business or industrial environments.
- Class B is typically for residential environments.

Information Technology Equipment (ITE), including peripherals, expansion cards, printers, input/output (I/O) devices, monitors, and so on, that are integrated into or connected to the system should match the electromagnetic environment classification of the end-user location.

NOTE: Product changes or modifications not expressly approved by Dell Inc. could void your authority to operate this equipment.

A Notice about Shielded Signal Cables: Use only shielded cables for connecting peripherals to any Dell device to reduce the possibility of interference with radio communications services. Using shielded cables ensures that you maintain the appropriate EMC classification for the intended environment. For parallel printers, a cable is available from Dell. If you prefer, you can order a cable from Dell on the World Wide Web at [www.dell.com](http://www.dell.com). Most Dell computer systems are classified for Class B environments. However, the inclusion of certain options can change the rating of some configurations to Class A.

Dell has determined that this product is an EMI/EMC Class B harmonized product. The following sections provide country-specific information for each regulatory agency.

---

## FCC Notices (U.S. Only)

### FCC, Class B

This equipment generates, uses, and can radiate radio frequency energy and, if not installed and used in accordance with the manufacturer's instruction manual, may cause interference with radio and television reception. This equipment has been tested and found to comply with the limits for a Class B digital device pursuant to Part 15 of the FCC Rules.

This device complies with Part 15 of the FCC Rules. Operation is subject to the following two conditions:

- This device may not cause harmful interference.
- This device must accept any interference received, including interference that may cause undesired operation.

 **NOTICE:** The FCC regulations provide that changes or modifications not expressly approved by Dell Inc. could void your authority to operate this equipment.

These limits are designed to provide reasonable protection against harmful interference in a residential installation. However, there is no guarantee that interference will not occur in a particular installation. If this equipment does cause harmful interference with radio or television reception, which can be determined by turning the equipment off and on, you are encouraged to try to correct the interference by one or more of the following measures:

- Reorient the receiving antenna.
- Relocate the device with respect to the receiver.
- Move the device away from the receiver.
- Plug the device into a different outlet so that the device and the receiver are on different branch

circuits.

If necessary, consult a representative of Dell Inc. or an experienced radio/television technician for additional suggestions.

The following information is provided on the device or devices covered in this document in compliance with FCC regulations

:

• Product Name:	Dell Color Printer 725
• Company Name:	Dell Inc. Worldwide Regulatory Compliance & Environmental Affairs One Dell Way Round Rock, Texas 78682 USA 512-338-4400

---

## Industry Canada (Canada Only)

### Industry Canada, Class B

This Class B digital apparatus complies with Canadian ICES-003.

Cet appareil numérique de la classe B est conforme à la norme NMB-003 du Canada.



**NOTICE:** The Industry Canada regulations provide that changes or modifications not expressly approved by Dell Inc. could void your authority to operate this equipment.

---

## CE Notice (European Union)

### European Union, Class B

This Dell device is classified for use in a typical Class B domestic environment.

A "Declaration of Conformity" in accordance with the preceding directives and standards has been made and is on file at Dell Inc. Products Europe BV, Limerick, Ireland.

---

## VCCI Notice (Japan Only)

## VCCI, Class B

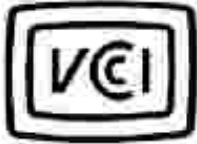

この装置は、情報処理装置等電波障害自主規制協議会（VCCI）の基準に基づくクラスB情報技術装置です。この装置は、家庭環境で使用することを目的としていますが、この装置がラジオやテレビジョン受信機に近接して使用されると、受信障害を引き起こすことがあります。  
取扱説明書に従って正しい取り扱いをして下さい。

## MIC Notice (Republic of Korea Only)

### MIC, Class B

As this equipment has obtained EMC registration for household use, it can be used in any area including residential area.

이 기기는 가정용으로 전자파적합등록을 한 기기로서 주거 지역에서는 물론 모든 지역에서 사용할 수 있습니다.

The following information is provided on the device or devices covered in this document in compliance with MIC regulations:

• Certificant Recipient:	Dell Inc. Worldwide Regulatory Compliance & Environmental Affairs One Dell Way Round Rock, Texas 78682 USA 512-338-4400
• Equipment or Model Name:	Dell Color Printer 725
• Certification Number:	See product label.
• Manufacturer Nation:	China
• Manufacturing Date:	Imprinted on product label.

## NOM I Information (Mexico Only)

The following information is provided on the device(s) described in this document in compliance with the requirements of the official Mexican standards (NOM):

Exporter:	Dell Inc. One Dell Way Round Rock, TX 78682
Importer:	Dell Computer de México, S.A. de C.V. Paseo de la Reforma 2620 - 11° Piso Col. Lomas Altas 11950 México, D.F.
Ship to:	Dell Computer de México, S.A. de C.V. al Cuidado de Kuehne & Nagel de México S. de R.L. Avenida Soles No. 55 Col. Peñon de los Baños 15520 México, D.F.
Model number:	725
Supply voltage:	100-240 VAC
Frequency:	50-60 Hz
Current consumption:	1.0 A
Output voltage:	30 VDC
Output current:	0.5 A

## ENERGY STAR® Compliance

Any Dell product bearing the ENERGY STAR® emblem on the product or on a start-up screen is certified to comply with Environmental Protection Agency (EPA) ENERGY STAR® requirements as configured when shipped by Dell. You can also help reduce electricity usage and its side effects by turning off your product when it is not in use for extended periods of time, particularly at night and on weekends.

## ENERGY STAR® Emblem



## Waste Electrical and Electronic Equipment (WEEE)



## Directive



In the European Union, this label indicates that this product should not be disposed of with household waste. It should be deposited at an appropriate facility to enable recovery and recycling. For information on how to recycle this product responsibly in your country, please visit: [www.euro.dell.com/recycling](http://www.euro.dell.com/recycling).

---



: [www.euro.dell.com/recycling](http://www.euro.dell.com/recycling).

---

## Diretiva WEEE (Waste from Electrical and Electronic Equipment)



Na União Européia, essa etiqueta indica que o produto não deve ser descartado junto com o lixo normal. Ele deve ser depositado em uma instalação apropriada para coleta e reciclagem. Para obter informações sobre como reciclar este produto de forma responsável em seu país, visite: [www.euro.dell.com/recycling](http://www.euro.dell.com/recycling).

---

## Smernice o odpadních elektrických a elektronických zařízeních (WEEE)



V Evropské unii tento štítek označuje, že tento produkt nesmí být likvidován s běžným komunálním odpadem. Je třeba předat jej do příslušného zařízení za účelem renovace a recyklace. Informace o recyklaci tohoto produktu ve vaší zemi naleznete na adrese: [www.euro.dell.com/recycling](http://www.euro.dell.com/recycling).

---

## WEEE-direktiv (Waste from Electrical and Electronic Equipment)



I EU angiver denne etiket, at produktet ikke må bortskaffes sammen med husholdningsaffald. Det skal afleveres på en facilitet, som er ansvarlig for gendannelse og genbrug. Oplysninger om ansvarlig genbrug af dette produkt i dit land finder du på: [www.euro.dell.com/recycling](http://www.euro.dell.com/recycling).

---

## Richtlijn WEEE, afdanken van elektrische en elektronische apparaten



In de Europese Unie geeft dit label aan dit product niet via huishoudelijk afval mag worden afgedankt. Het moet gedeponereerd worden bij een daarvoor geschikte voorziening zodat recuperatie en recyclage mogelijk zijn. Raadpleeg voor informatie over de milieuvriendelijke wijze van recyclage van dit product in uw land: [www.euro.dell.com/recycling](http://www.euro.dell.com/recycling).

---

## WEEE-direktiivi käytöstä poistettujen laitteiden hävittämisestä



Euroopan unionissa tämä merkintä kertoo, että tuote tulee hävittää kotitalousjätteen mukana. Se tulee hävittää niin, että se voidaan noutaa ja siirtää kierrätykseen. Lisätietoja maakohtaisesta jätteenkäsittelyohjeista on sivustossa [www.euro.dell.com/recycling](http://www.euro.dell.com/recycling).

---

## Directive sur les déchets d'équipements électriques et électroniques (DEEE)



Dans l'Union européenne, cette étiquette indique que le produit ne doit pas être mis au rebus avec des déchets ménagers. Vous devez le déposer dans un lieu destiné à la récupération et au recyclage de tels déchets. Pour de plus amples informations sur le recyclage de ce produit dans votre pays, vous pouvez consulter notre site à l'adresse suivante : [www.euro.dell.com/recycling](http://www.euro.dell.com/recycling).

---

## Richtlinie für Abfall von elektrischen und elektronischen Geräten (WEEE)



In der Europäischen Union bedeutet diese Markierung, dass dieses Produkt nicht mit dem Hausmüll entsorgt werden sollte. Es sollte zu einer sachgemäßen Einrichtung gebracht werden, um Wiedergewinnung und Recycling zu ermöglichen. Weitere Informationen über das verantwortungsbewusste Recyceln dieses Produkts erhalten Sie unter: [www.euro.dell.com/recycling](http://www.euro.dell.com/recycling).

---

μ  
μ (WEEE)



: [www.euro.dell.com/recycling](http://www.euro.dell.com/recycling).

---

## Waste Electrical and Electronic Equipment (WEEE) Directive



[www.euro.dell.com/recycling](http://www.euro.dell.com/recycling).

---

## Direttiva WEEE (Waste from Electrical and Electronic Equipment)



Nell'Unione Europea, questa etichetta indica che il prodotto non deve essere smaltito insieme ai rifiuti solidi urbani. Il prodotto deve essere depositato in un impianto appropriato per consentirne il recupero e il riciclaggio. Per informazioni su come riciclare questo prodotto in modo responsabile nel paese di appartenenza, visitare il sito all'indirizzo: [www.euro.dell.com/recycling](http://www.euro.dell.com/recycling).

---

## EE-direktivet (direktivet om elektrisk og elektronisk avfall)



I EU indikerer dette merket at dette produktet ikke skal kastes sammen med vanlig restavfall. Det bør avhendes ved et egnet anlegg slik at det kan gjenvinnes og resirkuleres. Du finner mer informasjon om hvordan du kan resirkulere dette produktet på en sikker måte i ditt land, på [www.euro.dell.com/recycling](http://www.euro.dell.com/recycling).

---

## Dyrektywa w sprawie zużytego sprzętu elektrycznego i elektronicznego (WEEE)



W Unii Europejskiej etykieta ta oznacza, że tego produktu nie należy wyrzucać wraz z odpadami z gospodarstwa domowego. Należy go przekazać do odpowiedniego zakładu, gdzie zostanie poddany odzyskowi i recyklingowi. Informacje o sposobie odpowiedzialnego recyklingu tego produktu w danym kraju można znaleźć pod adresem [www.euro.dell.com/recycling](http://www.euro.dell.com/recycling).

---

(WEEE)



[www.euro.dell.com/recycling](http://www.euro.dell.com/recycling)

---

## Directiva sobre el desecho de material eléctrico y electrónico (WEEE)



En la Unión Europea, esta etiqueta indica que la eliminación de este producto no se puede hacer junto con el desecho doméstico. Se debe depositar en una instalación apropiada que facilite la recuperación y el reciclado. Para obtener más información sobre cómo reciclar este producto de manera responsable en su país, visite el sitio Web: [www.euro.dell.com/recycling](http://www.euro.dell.com/recycling).

---

## WEEE-direktivet (Waste from Electrical and Electronic Equipment)



Inom EU indikerar den här etiketten att produkten får inte slängas med hushållsavfall. Den ska lämnas in på en återvinningsstation. Information om hur produkten återvinns i ditt land finns på: [www.euro.dell.com/recycling](http://www.euro.dell.com/recycling).

---

## Atik Elektrikli ve Elektronik Donanimlar (WEEE) Direktifi



Avrupa Birliğinde, bu etiket bu ürünün ev atıkları ile birlikte atılmaması gerektiğini belirtir. Kurtarılabilmesi ve geri dönüştürülebilmesi için uygun bir tesise bırakılmalıdır. Bu ürünün ülkenizde sorumlu bir şekilde nasıl geri dönüştürüleceği ile ilgili bilgiler için, lütfen bu web adresini ziyaret edin: [www.euro.dell.com/recycling](http://www.euro.dell.com/recycling).



# Appendix

- [Dell Technical Support Policy](#)
  - [Contacting Dell](#)
  - [Warranty and Return Policy](#)
- 

## Dell Technical Support Policy

Technician-assisted technical support requires the cooperation and participation of the customer in the troubleshooting process and provides for restoration of the Operating System, application software and hardware drivers to the original default configuration as shipped from Dell, as well as the verification of appropriate functionality of the printer and all Dell-installed hardware. In addition to this technician assisted technical support, online technical support is available at Dell Support. Additional technical support options may be available for purchase.

Dell provides limited technical support for the printer and any Dell-installed software and peripherals. Support for third-party software and peripherals is provided by the original manufacturer, including those purchased and/or installed through Software & Peripherals (DellWare), ReadyWare, and Custom Factory Integration (CFI/DellPlus).

---

## Contacting Dell

You can access Dell Support at [support.dell.com](http://support.dell.com). Select your region on the WELCOME TO DELL SUPPORT page, and fill in the requested details to access help tools and information.

You can contact Dell electronically using the following addresses:

- World Wide Web  
[www.dell.com/](http://www.dell.com/)  
[www.dell.com/ap/](http://www.dell.com/ap/) (for Asian/Pacific countries only)  
[www.euro.dell.com](http://www.euro.dell.com/) (for Europe only)  
[www.dell.com/la/](http://www.dell.com/la/) (for Latin American countries)  
[www.dell.com/jp/](http://www.dell.com/jp/) (for Japan only)
- Anonymous file transfer protocol (FTP)  
[ftp.dell.com/](ftp://ftp.dell.com/)  
Log in as user: anonymous, and use your email address as your password.
- Electronic Support Service  
[mobile\\_support@us.dell.com](mailto:mobile_support@us.dell.com)  
[support@us.dell.com](mailto:support@us.dell.com)  
[apsupport@dell.com](mailto:apsupport@dell.com) (for Asian/Pacific countries only)  
[support.euro.dell.com](mailto:support.euro.dell.com) (for Europe only)  
[support.jp.dell.com/jp/jp/tech/email/](mailto:support.jp.dell.com/jp/jp/tech/email/) (for Japan only)
- Electronic Quote Service

sales@dell.com  
apmarketing@dell.com (for Asian/Pacific countries only)

- Electronic Information Service  
info@dell.com

---

## Warranty and Return Policy

Dell Inc. ("Dell") manufactures its hardware products from parts and components that are new or equivalent to new in accordance with industry-standard practices. For information about the Dell warranty for your printer, refer to the *Product Information Guide*.

# Licensing Notice

The printer resident software contains:

- Software developed and copyrighted by Dell and/or third parties
- Dell modified software licensed under the provisions of the GNU General Public License version 2 and the GNU Lesser General Public License version 2.1
- Software licensed under the BSD license and warranty statements

Click the title of the document you want to review:

- [BSD License and Warranty Statements](#)
- [GNU License](#)

The Dell modified GNU licensed software is free software; you can redistribute it and/or modify it under the terms of the licenses referenced above. These licenses do not provide you any rights to the Dell- or third-party-copyrighted software in this printer.

Since the GNU licensed software that the Dell modifications are based upon is supplied explicitly without warranty, use of the Dell modified version is similarly provided without warranty. See the warranty disclaimers in the referenced licenses for additional details.

To obtain source code files for the Dell modified GNU licensed software, launch the *Drivers and Utilities CD* that shipped with your printer and click Contact Dell, or refer to the "Contacting Dell" section of your *Owner's Manual*.